

INSTRUCTION MANUAL

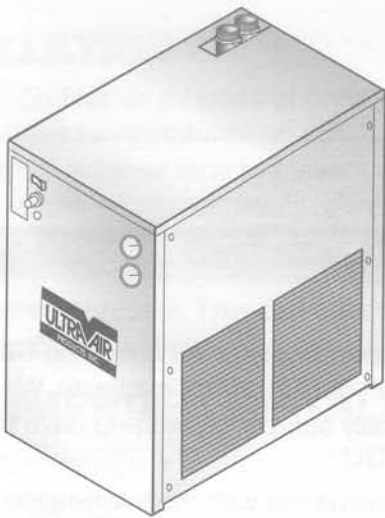
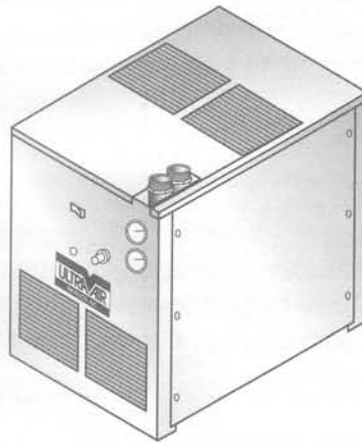

Model # _____

Serial # _____

Ship Date _____

REFRIGERATED AIR DRYERS
Models
UDR 20 thru UDR 100

**REFRIGERATED
AIR DRYERS**

Refrigerated Air Dryer

UDR Refrigerated Air Dryer Operators Instruction & Maintenance Manual

UDR 20 — UDR 100

Contents

Forward	2
Warnings	3
Receiving and Inspection	3
Installation	3
Drain Connections	4
Electrical Requirements	4
Controls	4
Panel Mounted Gauges	4
Indicating Lights	4
Initial Start-up	4
Start Up and Shut Down Procedures	5
Maintenance	5
Spare Parts List	6
Electrical Drawings	7
Trouble-Shooting & Service Chart	10

Operators Instruction and Maintenance Manual

Forward

This manual contains information and recommendations for installing, operating and servicing the Ultra Air UDR Refrigerated Air Dryer. Ultra Air Refrigerated Dryers are the highest quality dryers available. We back this claim with the longest warranty available in the industry. All units are totally self-contained and have been fully tested and inspected by Ultra Air before shipment from the factory.

The information, specifications and illustrations in this manual are in accordance with the information in effect at the time of printing. Ultra Air reserves the right to change design and specifications without notice and without incurring obligation.

Please read this manual carefully before locating and installing your dryer. Any questions or problems not covered herein may be directed to your Ultra Air dealer or to:

Ultra Air Products, Inc.
3309 John Conley Drive
Lapeer, MI 48446
Phone: (810) 667-6800
Fax: (810) 667-3622

Before calling make sure you have the Model Number and Serial Number on your dryer. The manufacturer will not be responsible for parts returned without proper authorization.

Refrigerated Air Dryer

Warnings

Only persons experienced and licensed to work on Electrical, Refrigeration and Compressed Air Systems should install or operate this equipment.

This entire manual should be read and understood before starting installing or operating this dryer. Before starting, installation and/or maintenance procedures, the main power must be turned off and the dryer must be depressurized of Compressed Air to 0 PSIG.

Do not remove, repair, or replace any item on this dryer while it is under pressure or the power is turned on. This dryer contains Refrigerant R134a or R22. Service personnel must be certified to handle R134a and R22 and comply to all Local, State and Federal Regulations concerning refrigerant when performing maintenance or service on this dryer.

Never operate this dryer above the maximum rated operating conditions. Operating above specified conditions will result in inferior performance and could damage the unit and/or cause personal injury.

Ultra Air Products, Inc. will not be responsible for removal, re-installation, down-time costs or consequential damages caused by the Refrigerated Air Dryer even if the possibility of such incidental or consequential damages has been made known to Ultra Air Products, Inc.

RECEIVING AND INSPECTION

Upon arrival, remove all packaging materials and inspect dryer carefully. Inspect cabinets for dents, inlet and outlet connections for damage, and skid for any oil due to refrigerant leaks. Inspect refrigerant gauges, they should read at least 40 PSIG and not be damaged. If they do not read at least 40 PSIG, do not start the dryer, contact the factory immediately. If any damage is found, report it to the freight company immediately.

INSTALLATION

Allow three (3) feet on all sides of dryer for service and proper air flow. The dryer should be installed in ambients where temperatures do not drop below +50°F or rise beyond 110°F. Dryers are normally installed downstream of receiver tank to prevent undue surging. Unit should be sitting level. Always select an installation site where ample ventilation exists, particularly for air-cooled condenser units. An adequate supply of outside air may be available by using an exhaust system to avoid recirculation of room air. An area with a high ambient temperature will effect the efficiency of an air-cooled condenser with a resultant increase in workload upon the refrigeration compressor. This can conceivably reduce the life of the equipment, and hinder its operation. Dryers operating in ambients lower than 50°F must be ordered with a Low Ambient Control Option.

RECOMMENDED INSTALLATION

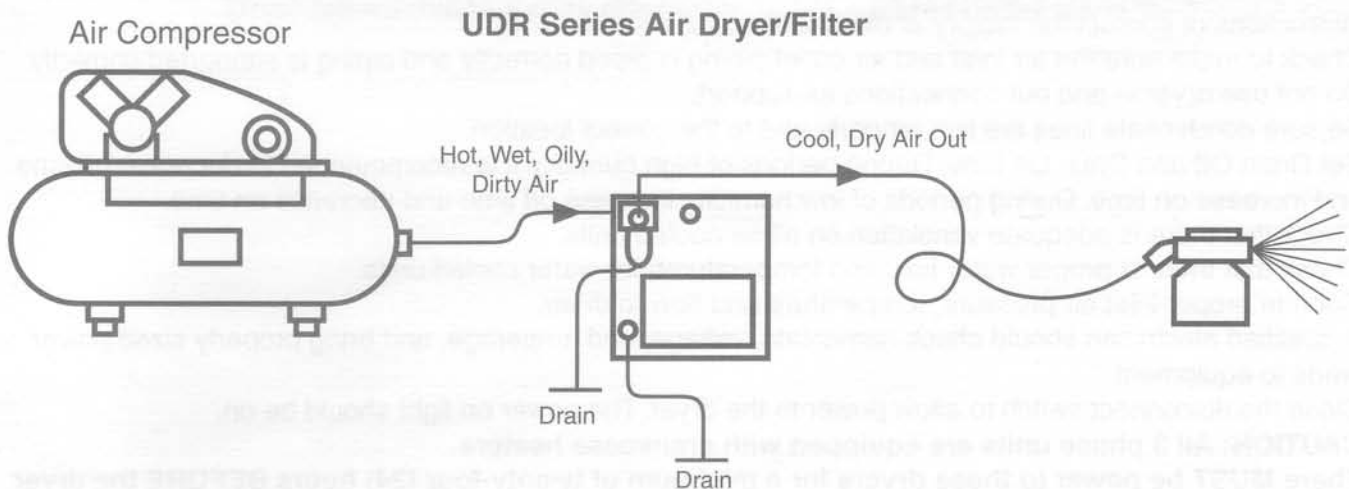

Refrigerated Air Dryer

DRAIN CONNECTIONS

Models UDR 20 through UDR 100 are equipped with solid state timer actuated electrical solenoid valve drain systems. The drain line from the dryer should be sloped and emptied into a floor drain or container that is lower than the bottom of the separator in the dryer, so that the condensate that is removed by the dryer can be drained away by gravity.

ELECTRICAL REQUIREMENTS

The nameplate on the instrument panel of each unit identifies the power supply requirements. A suitable wall mounted disconnect switch in accordance with National and Local Code requirements is recommended.

CONTROLS

1. **Filter-Dryer**
Filters refrigerant of moisture or any foreign particles; must be replaced if Refrigerant System is worked on.
2. **Thermostatic Expansion Valve**
Monitors and maintains the evaporating pressure/temperature, resulting in a constant dewpoint for the user.
3. **Hot Gas Bypass Valve**
Passes High side Gas to Low side to maintain a desired suction pressure.

PANEL MOUNTED GAUGES

1. **Refrigerant Suction Pressure**
Indicates pressure on Low side of Refrigerant Compressor. R22 units normally indicate between 60-65 PSIG. Range of gauge 30" vac/200 PSIG. R134a units normally indicate between 30-32 PSIG.
2. **Refrigerant Discharge Pressure Gauge (UDR 80 and 100 only)**
Indicates pressure on the High side of the refrigeration system, (R22 air cooled 220 PSIG) (R134a air cooled indicate 115 PSIG)
3. **Air Oil Pressure Gauge (UDR 80 and 100 only)**
Should indicate approximately what the compressor discharge pressure is.

INDICATING LIGHTS

1. **Power On Indicator**
A light indicates there is power to the dryer.

INITIAL START UP

The following procedures must be followed. Failure to do so could damage your dryer and invalidate the warranty. **BEFORE START:**

1. Be sure dryer "ON/OFF" switch is in the "OFF" position, or the dryer is unplugged.
2. If refrigerant gauges read below 40 PSIG do not start dryer. Contact your Ultra Air Distributor for further instructions or contact the factory at (313) 368-8500.
3. Check to make sure the air inlet and air outlet piping is piped correctly and piping is supported correctly. Do not use dryer in and out connections as support.
4. Be sure condensate lines are run properly and to the correct location.
5. Set Drain Off and Drain On time: During periods of high humidity it is recommended to decrease off time and increase on time. During periods of low humidity increase off time and decrease on time.
6. Check that there is adequate ventilation on all air cooled units.
7. Check that there is proper water flow and temperatures for water cooled units.
8. Confirm proper inlet air pressure, temperature and flow to dryer.
9. A qualified electrician should check nameplate, voltage, and amperage, and bring properly sized power leads to equipment.
10. Close the disconnect switch to allow power to the dryer. The power on light should be on.
11. **CAUTION: All 3 phase units are equipped with crankcase heaters.**
There MUST be power to these dryers for a minimum of twenty-four (24) hours BEFORE the dryer is turned on. Failure to do so will damage the dryer and void the warranty.

START PROCEDURES

1. Turn "ON/OFF" switch to the "ON" position and let run for approximately five (5) minutes (or plug unit in).
2. Pressurize the unit by opening the air inlet valve only.
3. When the refrigerant compressor starts, the suction pressure should drop to 30-32 PSIG for R134a and 60-65PSIG for R22 units. If this does not happen, contact your Ultra Air Distributor.

SHUT DOWN PROCEDURES

1. Turn compressor "ON" switch to "OFF".
2. Disconnect main power supply.
3. Lock out and tag disconnect switch in accordance with OSHA requirements.

DANGER

Disconnect electrical services from unit and make sure unit is depressurized whenever it is necessary to make repairs on timers or when servicing drain valves.

MAINTENANCE

1. Instructions for maintenance and cleaning of air-cooled refrigerant condensers:
Like any mechanical piece of equipment, your Refrigerant Air Dryer must be regularly maintained. Air-cooled condensers may be cleaned by:
 - A. Blowing clean with compressed air blow gun.
 - B. Steam cleaning may be necessary for heavy deposits. DO NOT use wire brushes as they may bend the fins and cause leaks.
 - C. Straighten bent fins and fan blades.
 - D. Recommended service interval is 800 hours of operation. More frequent service may be required if dryer is in a dusty or dirty area.
 - E. Ambient air filters are required for dryers located in any excessively dirty environment, and should be replaced if dirty.
2. Automatic Drains
 - A. Observe auto drain daily to make sure it is discharging condensate.
 - B. Periodically remove auto drain from separator bowl and wash with soapy water.
DANGER: Always be sure dryer is depressurized to 0 PSIG when removing **SEPARATOR BOWL**.

Dryer failure due to a dirty condenser is not covered under warranty.

Refrigerated Air Dryer

SPARE PARTS LIST

MODEL NUMBER	UDR 20 & UDR 30 115/1 & 115/1	UDR 40 115/1/60	UDR 60 230/3/60	UDR 60 460/3/60	UDR 60 575/3/60
DESCRIPTION	PART NUMBER	PART NUMBER	PART NUMBER	PART NUMBER	PART NUMBER
HOT GAS BYPASS	N/A	N/A	N/A	N/A	N/A
LIQUID LINE FILTER	FIL-LQ-31-4-RF	FIL-LQ-33-7-RF	FIL-LQ-33-7-RF	FIL-LQ-5-R4	FIL-LQ-5-R4
REF. SUCTION GAUGE	GAG-PR-21-4-P2	GAG-PR-21-4-P2	GAG-PR-21-4-P2	GAG-PR-21-4-P2	GAG-PR-21-4-P2
REF. DISCHARGE GAUGE	N/A	N/A	N/A	N/A	N/A
ON/OFF SWITCH	ELE-SI-65-88-P1	ELE-SI-65-88-P1	ELE-SI-65-88-P1	ELE-SI-65-88-P1	ELE-SI-65-88-P1
COMPRESSOR	COM-TG-4-SF1	COM-TG-33-SF1	COM-TG-7-SF2	COM-TG-15-70-2R	COM-TG-15-70-2R
FAN MOTOR	MOT-810M006B45	MOT-810M006B45	MOT-810M009B47	MOT-810F050B51	MOT-810F050B51
FAN BLADE	CON-BF-4-TF1	CON-BF-33-R3	CON-BF-33-SF1	CON-BF-15-TF1	CON-BF-15-TF1
HIGH PRESSURE CONTROL	N/A	N/A	N/A	N/A	N/A
LOW PRESSURE CONTROL	N/A	N/A	N/A	N/A	N/A
CRANKCASE HEATER	N/A	N/A	N/A	N/A	N/A
FLOAT DRAIN	FIL-DR-28-A2	DR-1F-0-RF	DR-1F-0-RF	N/A	N/A
OVERLOAD	COM-OV-32-SF1	ELE-OV-33-SF1	ELE-OV-7-SF2	N/A	N/A
RELAY	ELE-RY-4-SF1	ELE-RY-33-SF1	ELE-RY-7-SF2	N/A	N/A
CONTACTOR	N/A	N/A	N/A	ELE-AC-15-TF1	ELE-AC-15-TF2
SEPARATOR	FIL-SP-5-00	FIL-SP-9-A5	FIL-SP-9-A5	FIL-SP-9-A5	FIL-SP-9-A7
CAPACITOR, START	N/A	N/A	COM-C1-7-SF1	N/A	N/A
CONDENSOR	CON-AR-32-R3	CON-AR-33-R3	CON-AR-7-R3	CON-AR-15-R2	CON-AR-15-R2
TRANSFORMER .05 KVA	N/A	N/A	N/A	N/A	N/A
THERMAL EXPANSION VALVE	VAL-RB-4-5-R3	VAL-RB-4-5-R3	VAL-RB-4-5-R3	VAL-TH-9-15-R4	VAL-TH-9-15-R4
DRAIN TIMER	N/A	N/A	N/A	ELE-TB-85-T8	ELE-TB-85-T8
SOLENOID VALVE	N/A	N/A	N/A	VAL-SO-4-59-N8	VAL-SO-4-59-N8
TRANSFORMER 1 KVA	N/A	N/A	N/A	N/A	ELE-TR-11-V9
10 AMP FUSE	N/A	N/A	N/A	N/A	ELE-FS-30-TE

MODEL NUMBER	UDR 60 115/1/60	UDR 60 230/1/60	UDR 60 230/3/60	UDR 60 460/3/60	UDR 60 575/3/60
DESCRIPTION	PART NUMBER	PART NUMBER	PART NUMBER	PART NUMBER	PART NUMBER
HOT GAS BYPASS	N/A	N/A	N/A	N/A	N/A
LIQUID LINE FILTER	FIL-LQ-33-7-RF	FIL-LQ-33-7-RF	FIL-LQ-5-R4	FIL-LQ-5-R4	FIL-LQ-5-R4
REF. SUCTION GAUGE	GAG-PR-21-4-P2	GAG-PR-21-4-P2	GAG-PR-21-4-P2	GAG-PR-21-4-P2	GAG-PR-21-4-P2
REF. DISCHARGE GAUGE	N/A	N/A	N/A	N/A	N/A
ON/OFF SWITCH	ELE-SI-65-88-P1	ELE-SI-65-88-P1	ELE-SI-65-88-P1	ELE-SI-65-88-P1	ELE-SI-65-88-P1
COMPRESSOR	COM-TG-7-SF1	COM-TG-7-SF2	COM-TG-15-60-2R	COM-TG-15-70-2R	COM-TG-15-70-2R
FAN MOTOR	MOT-810M009B48	MOT-810M009B47	MOT-810S050A99	MOT-810F050B51	MOT-810F050B51
FAN BLADE	CON-BF-33-SF1	CON-BF-33-SF1	CON-BF-15-TF1	CON-BF-15-TF1	CON-BF-15-TF1
HIGH PRESSURE CONTROL	N/A	N/A	N/A	N/A	N/A
LOW PRESSURE CONTROL	N/A	N/A	N/A	N/A	N/A
CRANKCASE HEATER	N/A	N/A	N/A	N/A	N/A
FLOAT DRAIN	DR-1F-0-RF	DR-1F-0-RF	N/A	N/A	N/A
OVERLOAD	ELE-OV-7-SF1	ELE-OV-7-SF2	N/A	N/A	N/A
RELAY	ELE-RY-7-SF1	ELE-RY-7-SF2	N/A	N/A	N/A
CONTACTOR	N/A	N/A	ELE-AC-15-TF1	ELE-AC-15-TF2	ELE-AC-15-TF2
SEPARATOR	FIL-SP-9-A5	FIL-SP-9-A5	FIL-SP-9-A5	FIL-SP-9-A5	FIL-SP-9-A7
CAPACITOR, START	COM-C1-7-SF1	COM-C1-7-SF2	N/A	N/A	N/A
CONDENSOR	CON-AR-7-R3	CON-AR-7-R3	CON-AR-15-R2	CON-AR-15-R2	CON-AR-15-R2
TRANSFORMER .05 KVA	N/A	N/A	N/A	N/A	N/A
THERMAL EXPANSION VALVE	VAL-RB-4-5-R3	VAL-RB-4-5-R3	VAL-TH-9-15-R4	VAL-TH-9-15-R4	VAL-TH-9-15-R4
DRAIN TIMER	N/A	N/A	N/A	ELE-TB-85-T8	ELE-TB-85-T8
SOLENOID VALVE	N/A	N/A	VAL-SO-4-60-N8	VAL-SO-4-59-N8	VAL-SO-4-59-N8
TRANSFORMER 1 KVA	N/A	N/A	N/A	N/A	ELE-TR-11-V9
10 AMP FUSE	N/A	N/A	N/A	N/A	ELE-FS-30-TE

MODEL NUMBER	UDR 80 115/1/60	UDR 80 230/1/60	UDR 80 230/3/60	UDR 80 460/3/60	UDR 80 575/3/60
DESCRIPTION	PART NUMBER	PART NUMBER	PART NUMBER	PART NUMBER	PART NUMBER
HOT GAS BYPASS	VAL-HG-7-R5	VAL-HG-7-R5	VAL-HG-7-R5	VAL-HG-7-R5	VAL-HG-7-R5
LIQUID LINE FILTER	FIL-LQ-5-R4	FIL-LQ-5-R4	FIL-LQ-5-R4	FIL-LQ-5-R4	FIL-LQ-5-R4
REF. SUCTION GAUGE	GAG-PR-21-4-P2	GAG-PR-21-4-P2	GAG-PR-21-4-P2	GAG-PR-21-4-P2	GAG-PR-21-4-P2
REF. DISCHARGE GAUGE	GAG-PR-21-4-P1	GAG-PR-21-4-P1	GAG-PR-21-4-P1	GAG-PR-21-4-P1	GAG-PR-21-4-P1
ON/OFF SWITCH	ELE-SI-65-88-P1	ELE-SI-65-88-P1	ELE-SI-65-88-P1	ELE-SI-65-88-P1	ELE-SI-65-88-P1
COMPRESSOR	COM-TG-7-SF1	COM-TG-7-SF2	COM-TG-15-60-2R	COM-TG-15-70-2R	COM-TG-15-70-2R
FAN MOTOR	MOT-810M009B48	MOT-810M009B47	MOT-810S050A99	MOT-810F050B51	MOT-810F050B51
FAN BLADE	CON-BF-33-TF1	CON-BF-33-TF1	CON-BF-15-TF1	CON-BF-15-TF1	CON-BF-15-TF1
HIGH PRESSURE CONTROL	N/A	N/A	N/A	N/A	N/A
LOW PRESSURE CONTROL	N/A	N/A	N/A	N/A	N/A
CRANKCASE HEATER	N/A	N/A	N/A	N/A	N/A
FLOAT DRAIN	N/A	N/A	N/A	N/A	N/A
OVERLOAD	ELE-OV-7-SF1	ELE-OV-7-SF2	N/A	N/A	N/A
RELAY	ELE-RY-7-SF1	ELE-RY-7-SF2	N/A	N/A	N/A
CONTACTOR	N/A	N/A	ELE-AC-15-TF2	ELE-AC-15-TF2	ELE-AC-15-TF2
SEPARATOR	FIL-SP-9-A7	FIL-SP-9-A7	FIL-SP-9-A7	FIL-SP-9-A7	FIL-SP-9-A7
CAPACITOR, START	COM-C1-7-SF1	COM-C1-7-SF2	N/A	N/A	N/A
CONDENSOR	CON-AR-7-R3	CON-AR-7-R3	CON-AR-15-R2	CON-AR-15-R2	CON-AR-15-R2
TRANSFORMER .05 KVA	N/A	N/A	N/A	N/A	N/A
THERMAL EXPANSION VALVE	VAL-TH-7-11-R3	VAL-TH-7-11-R3	VAL-TH-9-15-R4	VAL-TH-9-15-R4	VAL-TH-9-15-R4
DRAIN TIMER	ELE-TB-85-T8	ELE-TB-85-T8	ELE-TB-85-T8	ELE-TB-85-T8	ELE-TB-85-T8
SOLENOID VALVE	VAL-SO-4-59-N8	VAL-SO-4-60-N8	VAL-SO-4-60-N8	VAL-SO-4-59-N8	VAL-SO-4-59-N8
TRANSFORMER 1 KVA	N/A	N/A	N/A	N/A	ELE-TR-11-V9
10 AMP FUSE	N/A	N/A	N/A	N/A	ELE-FS-30-TE

MODEL NUMBER	UDR 100 115/1/60	UDR 100 230/1/60	UDR 100 230/3/60	UDR 100 460/3/60	UDR 100 575/3/60
DESCRIPTION	PART NUMBER	PART NUMBER	PART NUMBER	PART NUMBER	PART NUMBER
HOT GAS BYPASS	VAL-HG-7-R5	VAL-HG-7-R5	VAL-HG-7-R5	VAL-HG-7-R5	VAL-HG-7-R5
LIQUID LINE FILTER	FIL-LQ-5-R4	FIL-LQ-5-R4	FIL-LQ-5-R4	FIL-LQ-5-R4	FIL-LQ-5-R4
REF. SUCTION GAUGE	GAG-PR-21-4-P2	GAG-PR-21-4-P2	GAG-PR-21-4-P2	GAG-PR-21-4-P2	GAG-PR-21-4-P2
REF. DISCHARGE GAUGE	GAG-PR-21-4-P1	GAG-PR-21-4-P1	GAG-PR-21-4-P1	GAG-PR-21-4-P1	GAG-PR-21-4-P1
ON/OFF SWITCH	ELE-SI-65-88-P1	ELE-SI-65-88-P1	ELE-SI-65-88-P1	ELE-SI-65-88-P1	ELE-SI-65-88-P1
COMPRESSOR	COM-TG-9-SF1	COM-TG-9-SF2	COM-TG-15-60-2R	COM-TG-15-70-2R	COM-TG-15-70-2R
FAN MOTOR	ELE-FM-85-01	MOT-810M035A28	MOT-810S050A99	MOT-810F050B51	MOT-810F050B51
FAN BLADE	CON-BF-9-TF1	CON-BF-9-TF1	CON-BF-15-TF1	CON-BF-15-TF1	CON-BF-15-TF1
HIGH PRESSURE CONTROL	N/A	N/A	N/A	N/A	N/A
LOW PRESSURE CONTROL	N/A	N/A	N/A	N/A	N/A
CRANKCASE HEATER	N/A	N/A	N/A	N/A	N/A
FLOAT DRAIN	N/A	N/A	N/A	N/A	N/A
OVERLOAD	ELE-OV-9-SF1	ELE-OV-9-SF2	N/A	N/A	N/A
RELAY	ELE-RY-9-SF1	ELE-RY-9-SF2	N/A	N/A	N/A
CONTACTOR	N/A	N/A	ELE-AC-15-TF1	ELE-AC-15-TF2	ELE-AC-15-TF2
SEPARATOR	FIL-SP-9-A7	FIL-SP-9-A7	FIL-SP-9-A7	FIL-SP-9-A7	FIL-SP-9-A7
CAPACITOR, START	COM-C1-9-SF1	COM-C1-9-SF2	N/A	N/A	N/A
CONDENSOR	CON-AR-9-R3	CON-AR-9-R3	CON-AR-15-R2	CON-AR-15-R2	CON-AR-15-R2
TRANSFORMER .05 KVA	N/A	N/A	N/A	N/A	N/A
THERMAL EXPANSION VALVE	VAL-TH-7-11-R3	VAL-TH-7-11-R3	VAL-TH-9-15-R4	VAL-TH-9-15-R4	VAL-TH-9-15-R4
DRAIN TIMER	ELE-TB-85-T8	ELE-TB-85-T8	ELE-TB-85-T8	ELE-TB-85-T8	ELE-TB-85-T8
SOLENOID VALVE	VAL-SO-4-59-N8	VAL-SO-4-60-N8	VAL-SO-4-60-N8	VAL-SO-4-59-N8	VAL-SO-4-59-N8
TRANSFORMER 1 KVA	N/A	N/A	N/A	N/A	ELE-TR-11-V9
10 AMP FUSE	N/A	N/A	N/A	N/A	ELE-FS-30-TE

Refrigerated Air Dryer

ELECTRICAL DRAWINGS

UDR 20 AC and UDR 30 AC Refrigerated Dryer

MODEL #	VOLTAGE	REF. H.P.	F.L.A.	L.R.A.	MAX. FUSE SIZE
UDR 20 AC	115-1-60	1/4	6.9	28.0	15 AMPS
UDR 30 AC	115-1-60	1/4	6.9	28.0	15 AMPS

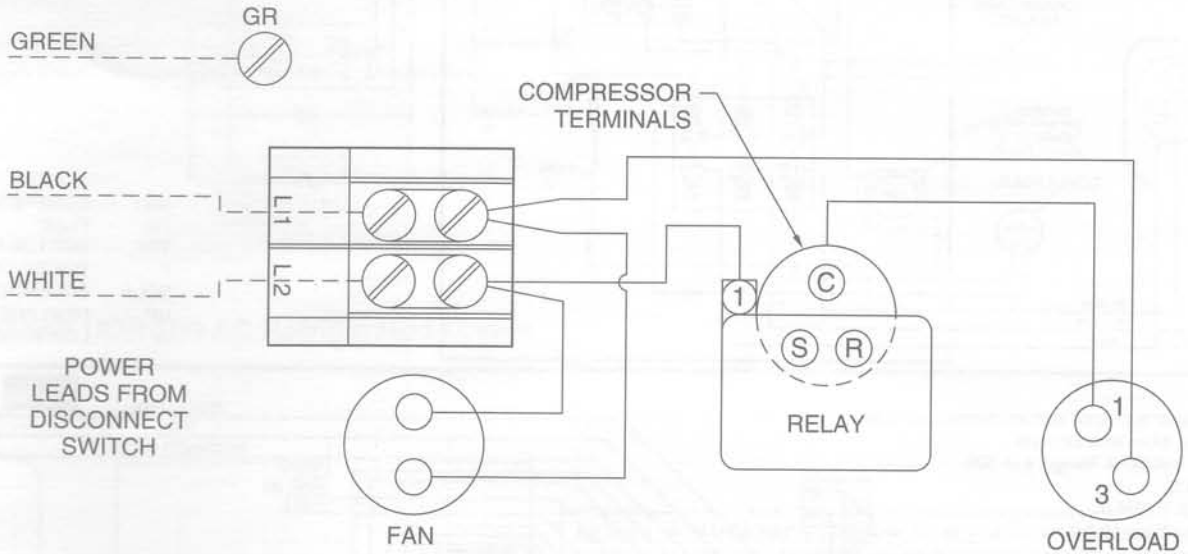

UDR 40 AC and UDR 60 AC Refrigerated Dryer

MODEL #	VOLTAGE	REF. H.P.	F.L.A.	L.R.A.	MAX. FUSE SIZE
UDR 40 AC	115-1-60	1/3	9.0	35.0	15 AMPS
UDR 40 AC	230-1-60	1/3	4.6	19.0	15 AMPS
UDR 60 AC	115-1-60	1/2	12.2	48.0	20 AMPS
UDR 60 AC	230-1-60	1/2	6.1	23.0	20 AMPS

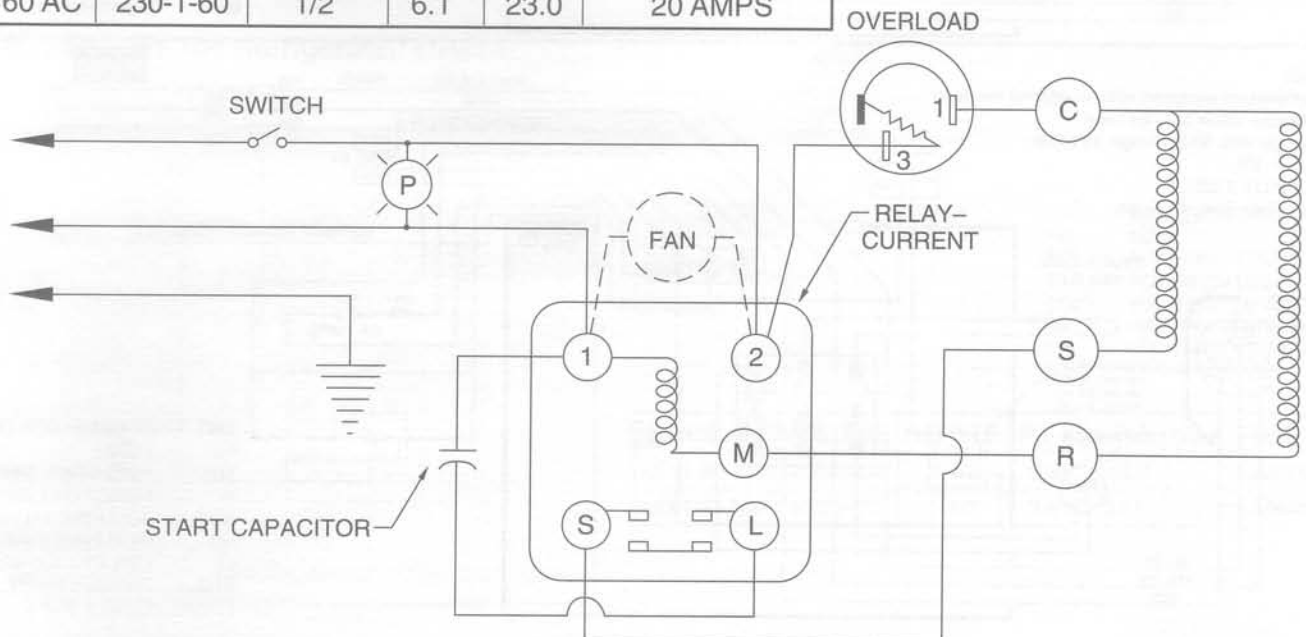

Refrigerated Air Dryer

ELECTRICAL DRAWINGS

UDR 60 Refrigerated Dryer

NOTES:

1. Compressor equipped with an internal overload protector. Allow time for reset.
2. Voltage: 230/208 - 60-3, Range: 187-253
3. H.P.: 1-1/2
4. RLA/FLR: 6.9/49.0
5. Max Fuse Size: 15 Amps

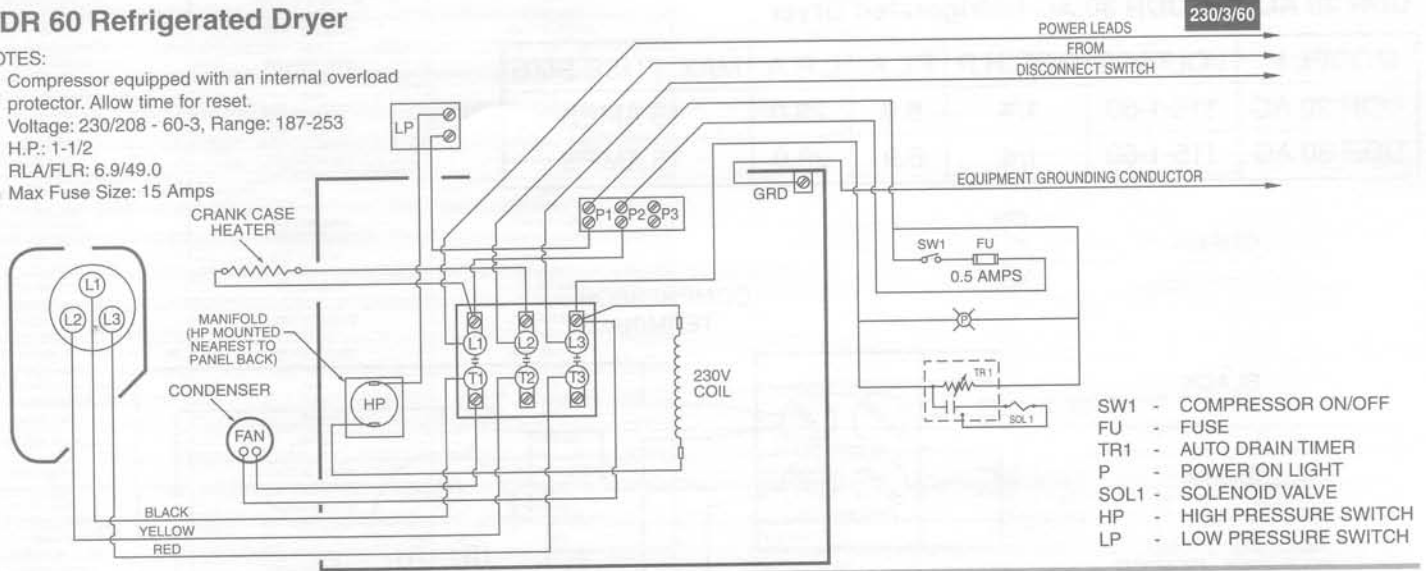

NOTES:

1. Compressor equipped with an internal overload protector. Allow time for reset.
2. Voltage: 460-60-3, Range: 414-506
3. H.P.: 1-1/2
4. RLA/FLR: 3.8/24.0
5. Max Fuse Size: 15 Amps

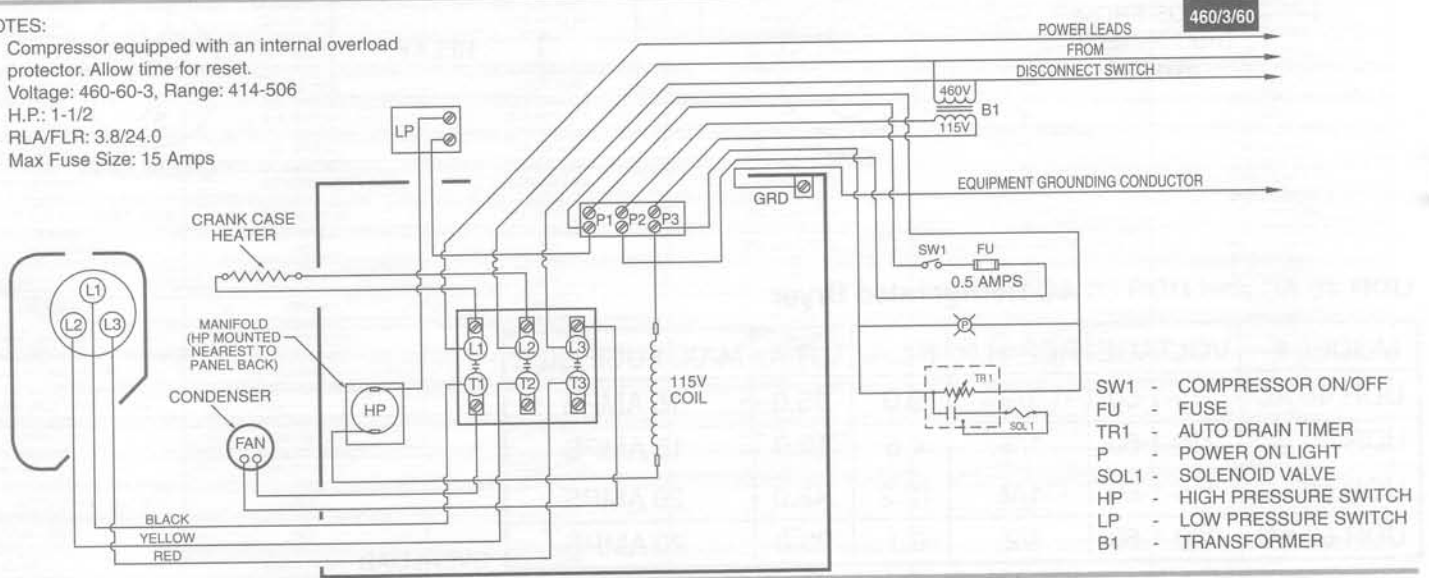

NOTES:

1. Compressor equipped with an internal overload protector. Allow time for reset.
2. Voltage: 460-60-3, Range: 414-506
3. H.P.: 1-1/2
4. RLA/FLR: 3.8/24.0
5. Max Fuse Size: 15 Amps

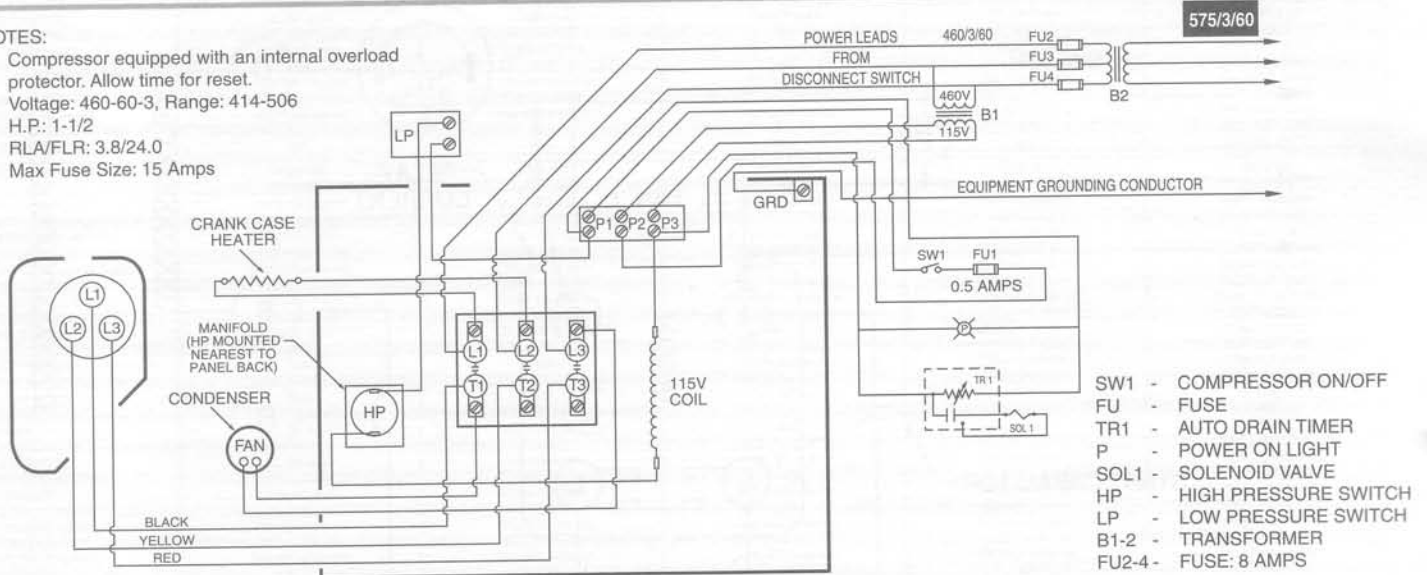

Refrigerated Air Dryer

ELECTRICAL DRAWINGS

575/3/60 Step Down Transformer

MODEL #	PART NO.	OLD PART NO.
UDR 80-100	ELE-TR-63-70-X1	11201-1

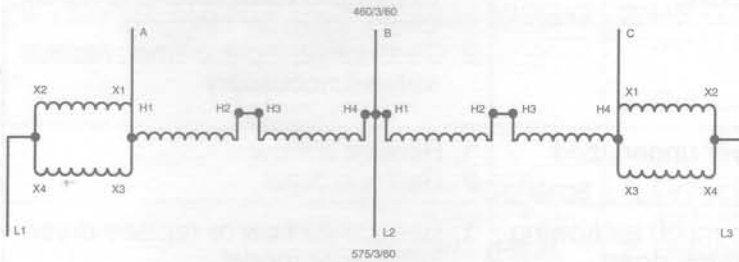

UDR 80 AC and UDR 100 AC Refrigerated Dryers

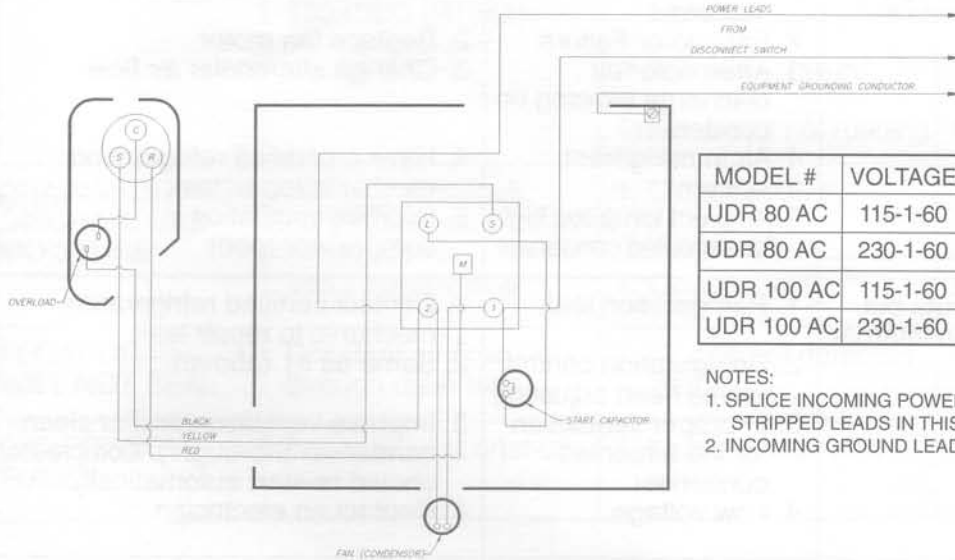

MODEL #	VOLTAGE	REF. H.P.	R.L.A.	L.R.A.	MAX. FUSE SIZE
UDR 80 AC	115-1-60	1/2	9.5	48.0	20 AMPS
UDR 80 AC	230-1-60	1/2	4.8	23.0	15 AMPS
UDR 100 AC	115-1-60	3/4	13.0	69.0	30 AMPS
UDR 100 AC	230-1-60	3/4	7.0	41.8	15 AMPS

NOTES:

1. SPLICE INCOMING POWER LEADS FROM DISCONNECT SWITCH, TO STRIPPED LEADS IN THIS ENCLOSURE.
2. INCOMING GROUND LEAD TO GREEN SCREW.

UDR 80 and UDR 100 Refrigerated Dryers

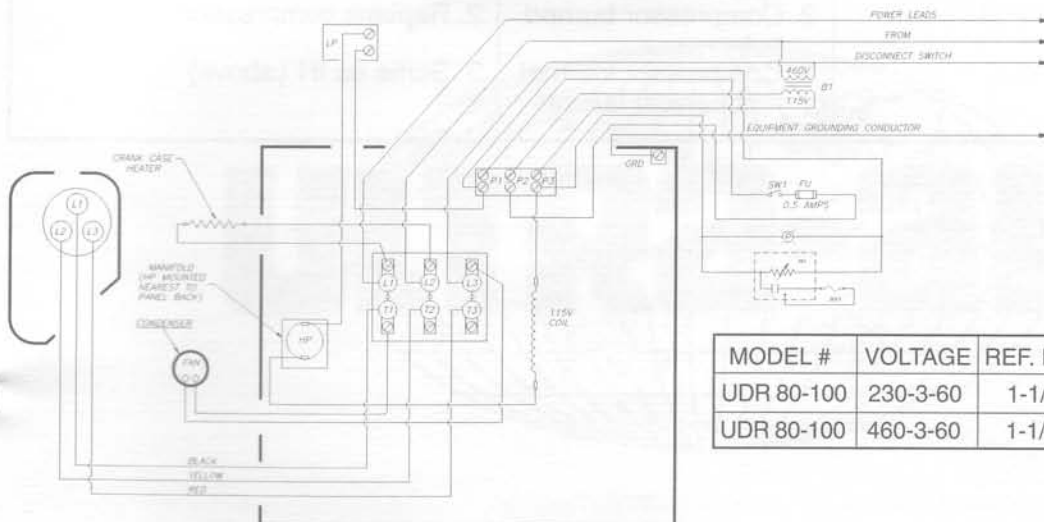

- SW1 - COMPRESSOR ON/OFF
- FU - FUSE
- TR1 - AUTO DRAIN TIMER
- P - POWER ON LIGHT
- SOL1 - SOLENOID VALVE
- HP - HIGH PRESSURE SWITCH
- LP - LOW PRESSURE SWITCH
- B1 - TRANSFORMER

MODEL #	VOLTAGE	REF. H.P.	R.L.A.	L.R.A.	MAX. FUSE SIZE
UDR 80-100	230-3-60	1-1/2	6.9	49.0	15 AMPS
UDR 80-100	460-3-60	1-1/2	3.8	24.0	15 AMPS

Refrigerated Air Dryer

TROUBLE-SHOOTING & SERVICE CHART

PROBLEM	SYMPTOM	POSSIBLE CAUSE	SOLUTION
LIQUID MOISTURE DOWNSTREAM OF DRYER	Drain not draining condensate	1. Drain valve not opening	1. Check drain electrically, is timer working, is valve receiving signal, check valve for clogging. 2. Clean valve, replace timer, replace valve if necessary
	High air flow through dryer	1. Dryer undersized	1. Reduce airflow 2. Replace dryer
	High pressure drop across dryer	1. Too much air flowing through dryer 2. Air freezing in air-to-refrigerant heat	1. Reduce air flow or replace dryer with larger model 2. Adjust hot gas by-pass valve
	Refrigerant compressor off from high refrigerant discharge pressure	1. Condenser coils clogged or fins flattened 2. Fan motor Failure 3. Aftercooler air discharge blowing on condenser 4. Air in refrigerant system 5. Ambient temp too high for aircooled condenser	1. Clean coils, straighten fins 2. Replace fan motor 3. Change aftercooler air flow 4. Have a certified refrigeration mechanic repair leak 5. Improve ventilation in compressor room
	Compressor cuts out, short cycles on internal overload	1. Refrigeration leak 2. Refrigeration control valves need adjusting 3. Improper ventilation for the aircooled condenser 4. Low voltage	1. Contact certified refrigeration mechanic to repair leak 2. Same as #1 (above) 3. Improve ventilation and/or clean condenser thoroughly. Compressor should re-start automatically 4. Contact an electrician
	Compressor will not start	1. Compressor windings opened or shorted. 2. Compressor burned out 3. Compressor internal mechanical failure	1. Contact refrigeration mechanic 2. Replace compressor 3. Same as #1 (above)

TROUBLE-SHOOTING & SERVICE CHART

PROBLEM	SYMPTOM	POSSIBLE CAUSE	SOLUTION
LIQUID MOISTURE DOWNSTREAM OF DRYER	Refrigeration suction pressure above 35 PSIG (R134a), 70 PSIG (R22)	<ol style="list-style-type: none"> 1. Inlet air temp higher than 120°F 2. Hot Gas Bypass Valve out of adjustment 3. Refrigerant leak 	<ol style="list-style-type: none"> 1. Check aftercooler operation 2. Adjust Hot Gas Bypass Valve by turning clockwise 1/2 turn until pressure lowers to 32 PSIG 3. Call refrigeration mechanic to repair leak
	Refrigeration discharge pressure is lower than 122-135 PSIG (R22), 65-70 PSIG (R134a)	<ol style="list-style-type: none"> 1. Dryer located in a low ambient 2. Refrigerant leak 	<ol style="list-style-type: none"> 1. Contact your distributor 2. Contact refrigeration mechanic to repair leak
	Refrigerant discharge pressure is above 300 PSIG (R22) 150 PSIG (R134a)	<ol style="list-style-type: none"> 1. Dryer located in a high ambient 2. Inlet air temp is too high 3. Fan motor failure 4. Fan motor not running 	<ol style="list-style-type: none"> 1. Contact your distributor 2. Check aftercooler operation. Reduce temperature to design conditions 3. Call refrigeration mechanic to repair leak 4. Check fan cycling switches
DRAIN VALVE NOT DISCHARGING MOISTURE	Valve continuously purges compressed air	<ol style="list-style-type: none"> 1. Clogged valve 	<ol style="list-style-type: none"> 1. Clean valve
	Valve not opening	<ol style="list-style-type: none"> 1. Clogged valve 	<ol style="list-style-type: none"> 1. Clean valve
FLOAT DRAIN WILL NOT SEAL	Constant air flow through drain tube	<ol style="list-style-type: none"> 1. Clogged or defective float 	<ol style="list-style-type: none"> 1. Replace float or clean float
DRYER BLOWS FUSES	Fuses blow at start-up	<ol style="list-style-type: none"> 1. Loose or defective wiring 	<ol style="list-style-type: none"> 1. Call electrician to inspect and repair



